

RLS/BP MX SERIES

RLS/BP MX series burners are characterised by a modular monoblock structure that means all necessary components can be combined in a single unit thus making installation easier, faster and, above all, more flexible.

The series covers a firing range from 1250 to 4500 kW, and they have been designed for use in hot water boilers, overheated water boilers as well as steam boilers. Burners working is 2 stages on the oil side and two stages progressive on the gas side. Alternatively the gas working can be modulating with the installation of a PID logic regulator. Using a particular proportioning gas valve the burner keeps the desired air/gas ratio in every working condition.

The innovative combustion head which is able to reach good performances in term of Low NOx either during gas working or light oil working and reducing noise.



RLS 300/BP MX	600/1250 ÷ 3650 kW
RLS 400/BP MX	800/2000 ÷ 4500 kW

FIRING RATES

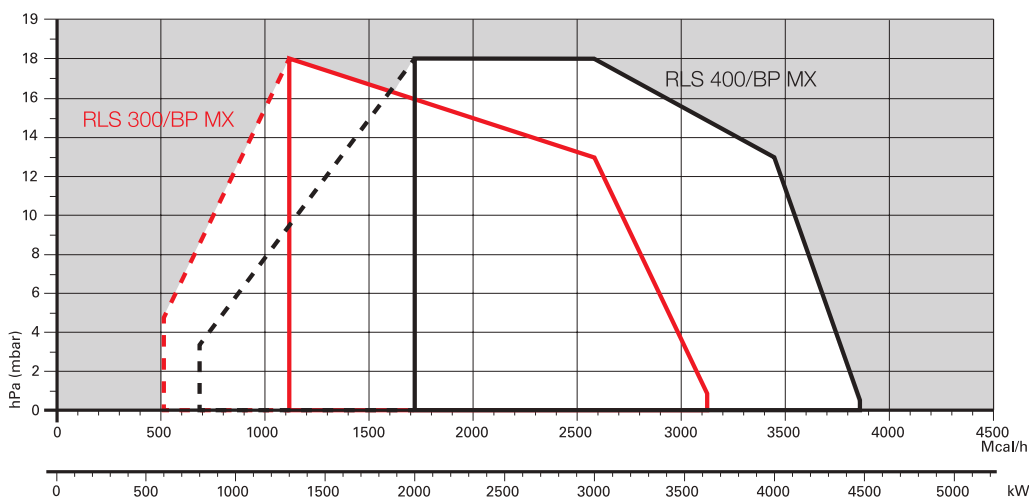

Low NOx Modulating Dual Fuel Burners

RLS/BP MX SERIES

Overall dimensions (mm)

BURNER

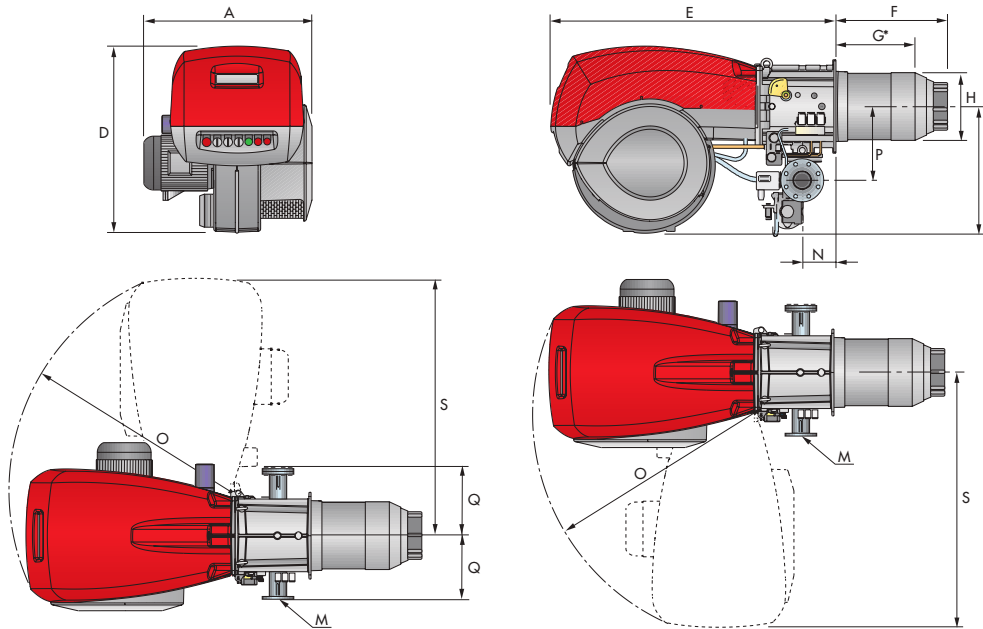

MODEL	A	D	E	F	G*	H	I	M	N	O	P	Q	S
▶ RLS 300/BP MX	720	890	1325	508	365	313	605	DN80	164	1055	342	320	1175
▶ RLS 400/BP MX	775	890	1325	508	365	313	605	DN80	164	1055	342	320	1175

* Maximum depth of the boiler door including the depth of the burner flange insulating gasket.

BURNER - BOILER MOUNTING FLANGE

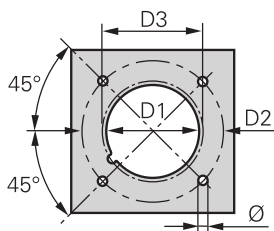

MODEL	D1	D2	D3	Ø
▶ RLS 300/BP MX	350	452	372	M18
▶ RLS 400/BP MX	350	452	372	M18

PACKAGING

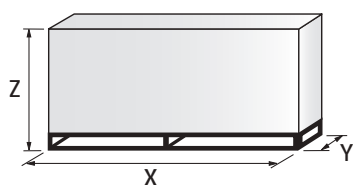

MODEL	X	Y	Z	kg
▶ RLS 300/BP MX	1960	970	1100	280
▶ RLS 400/BP MX	1960	970	1100	290

RLS/BP MX SERIES

Specification

DESIGNATION OF SERIES

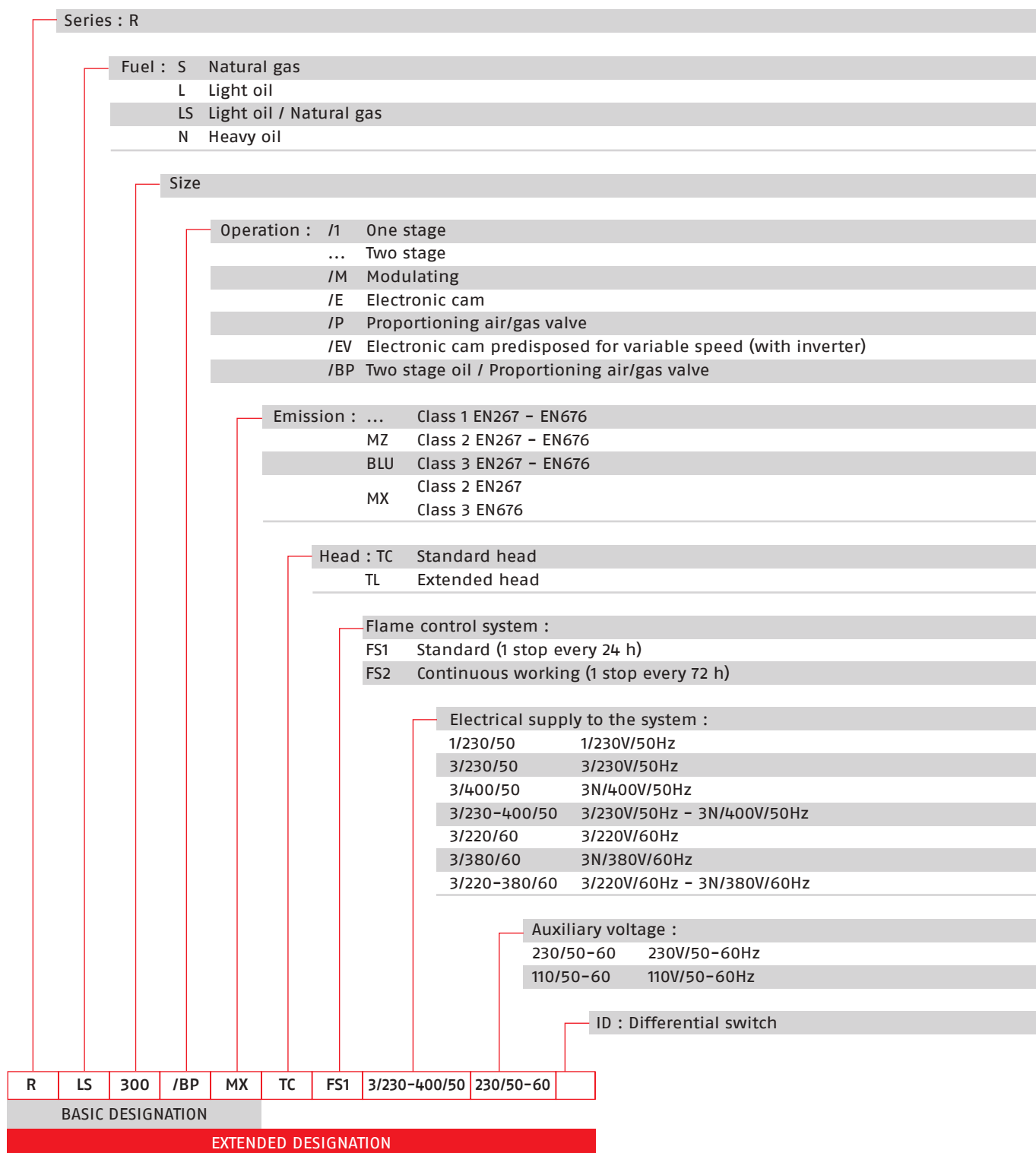

LOW NOx
DUAL FUEL

Low NOx Modulating Dual Fuel Burners

RLS/BP MX SERIES

Specification

STATE OF SUPPLY

Monoblock forced draught gas burner with "two stage progressive" or "modulating" operation, fully automatic, made up of:

- Fan with reverse curve blades high performance with low sound emissions
- Air suction circuit lined with sound-proofing material
- Air damper for air setting controlled by a high precision servomotor
- Air pressure switch
- Fan starting motor at 2800 rpm, three-phase 230/400 - 400/690 V with neutral, 50Hz
- Low emission combustion head, that can be set on the basis of required output, fitted with:
 - stainless steel end cone, resistant to corrosion and high temperatures
 - ignition electrodes
 - flame stability disk
- Maximum gas pressure switch, with pressure test point, for halting the burner in the case of over pressure on the fuel supply line
- Module for air/fuel setting and output modulation with separated PID control of temperature or pressure, available as accessory for RLS/BP MX model
- Burner safety control box for controlling the system safety
- Ionization probe for flame detector
- Star/delta starter for the fan motor (only for RLS 400/BP MX model)
- Main electrical supply terminal board
- Burner on/off switch
- Auxiliary voltage led signal
- Burner working led signal
- Contacts motor and thermal relay with release button
- Motor internal thermal protection
- Motor failure led signal
- Burner failure led signal and lighted release button
- Emergency button
- Coded connection plugs-sockets
- Lifting rings
- IP 54 electric protection level
- Gears pump for high pressure fuel supply
- Pump starting motor
- Oil safety valves
- Three oil valves (1st and 2nd stage 3rd safety valve)
- UV photocell for flame detection
- Oil/Gas selector
- Flame inspection window
- Burner opening hinge.

Standard equipment:

- 1 flange gasket
- 4 screws for fixing the flange
- 1 thermal screen
- 4 screws for fixing the burner flange to the boiler
- 2 flexible pipes for connection to the oil supply network
- 2 nipples for connection to the pump with gaskets.
- Instruction handbook for installation, use and maintenance
- Spare parts catalogue.

RLS/BP MX SERIES

Available models

Burners

CODE	MODEL	HEAT OUTPUT			TOTAL ELECTRICAL POWER (kW)	CERTIFICATION	NOTE
		(kW)	LIGHT OIL (kg/h)	NATURAL GAS (Nm ³ /h)			
3898510	RLS 300/BP MX TC FS1 3/230-400/50 230/50-60	600/1250-3650	50/105-308	60/125-365	7,	CE 0085 BP5534	
20006452	RLS 300/BP MX TC FS1 3/220-380/60 220/60	600/1250-3650	50/105-308	60/125-365	7	-	
3898612	RLS 400/BP MX TC FS1 3/400/50 230/50-60	800/2000-4500	68/169-380	80/200-450	10,5	CE 0085 BP5535	

Net calorific value light oil: 11,8 kWh/kg; 10.200 kcal/kg - Viscosity at 20°C: 4-6 mm²/s (cSt).

Net calorific value G20 gas: 10 kWh/Nm³; 8.600 kcal/Nm³ - Density: 0,71 kg/Nm³.

The burners of RLS/BP MX series are in according to 2009/142 - 2004/108 - 2006/95 - EC Directive and EN 267 - 676 Norm.

Gas Trains

COMPOSED GAS TRAIN	CODE	GAS TRAIN MODEL	∅	VPS CODE	ADAPTER CODE	NOTE
		3970215	VDG 50/P - FT 02	DN 80	3010367	3010222
	3970212	VDG 65/P - FT 02	DN 80	3010367	3010222	(1) (2)
	3970213	VDG 80/P - FT 02	DN 80	3010367	3010222	(1) (2)
	3970214	VDG 100/P - FT 02	DN 80	3010367	3010222	(1) (2)

Please see Designation of Gas Train Series in the page before the Catalogue index.

* Gas trains are 230V/50Hz - 220V/60Hz electrical supply.

** See adapter length on "Gas trains accessories" paragraph.

(1) Seal control to be ordered separately - see "Gas trains accessories" section.

(2) Adapter is necessary when the gas train has to be installed to the left of the burner to allow maintenance, or if is necessary to space out the gas train from burner.

The valve seal control device is compulsory (conforming to EN 676) on gas trains to burners with a maximum output over 1200 kW.

To select the gas train please refer to the technical data leaflet and/or instruction manual.

Low NOx Modulating Dual Fuel Burners

RLS/BP MX SERIES

Burner accessories

Nozzles type 60° B



The nozzles must be ordered separately. The following table shows the features and codes on the basis of the maximum required fuel output.

NOTE: each burner needs N° 2 nozzles.

BURNER	GPH	RATED OUTPUT (kg/h)			NOZZLE CODE
		at 10 bar	at 12 bar	at 14 bar	
► RLS/BP MX	12,00	44,2	48,7	53,0	3009950
► RLS/BP MX	13,00	47,8	52,8	57,4	3009951
► RLS/BP MX	14,00	51,5	56,9	61,8	3009952
► RLS/BP MX	15,00	55,2	60,9	66,2	3009953
► RLS/BP MX	16,00	58,9	65,0	70,6	3009954
► RLS/BP MX	17,00	62,6	69,0	75,0	3009955
► RLS/BP MX	18,00	66,2	73,1	79,4	3009956
► RLS/BP MX	19,00	69,9	77,2	83,5	3009957
► RLS/BP MX	20,00	73,6	81,2	88,3	3009958
► RLS/BP MX	22,00	81,0	89,3	97,1	3009959
► RLS/BP MX	24,00	88,3	97,5	105,9	3009960
► RLS/BP MX	26,00	95,7	105,6	114,7	3009961
► RLS/BP MX	28,00	103,1	113,7	123,6	3009962
► RLS/BP MX	30,00	110,4	121,8	132,4	3009963
► RLS/BP MX	35,00	128,8	142,1	154,5	3009964
► RLS/BP MX	40,00	147,2	162,4	176,5	3009965
► RLS/BP MX	45,00	165,6	182,7	198,6	3009966
► RLS/BP MX	50,00	184,0	203,0	220,7	3009967
► RLS/BP MX	55,00	202,4	223,4	242,7	3009968
► RLS/BP MX	60,00	220,8	243,7	264,8	3009969
► RLS/BP MX	65,00	239,2	264,0	286,9	3009970
► RLS/BP MX	70,00	257,6	284,3	309,0	3009971

Fuel remote selection kit



BURNER	KIT CODE
► RLS 300-400/BP MX	3010372

Spacer kit



If burner head penetration into the combustion chamber needs reducing, varying thickness spacers are available, as given in the following table:

BURNER	SPACER THICKNESS S (mm)	KIT CODE
► RLS 300-400/BP MX	180	20008903

Burner accessories

Continuous ventilation kit



If the burner requires continuous ventilation in the stages without flame, a special kit is available as given in the following table.

BURNER	KIT CODE
► RLS 300-400/BP MX	3010030

Sound proofing box

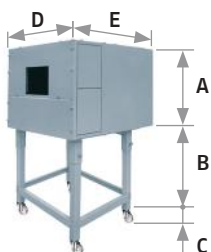

If noise emission needs reducing even further, sound-proofing boxes are available. In case of generator heights, where a lower dimension "B" is required, ask for the Box Support Kit code 20065135. The useful dimensions are 40 mm less than the total dimensions indicated in the table (A, D, E). Not suitable for outdoor use.

BURNER	BOX TYPE	A (mm)	B (mm) min-max	C (mm)	D (mm)	E (mm)	[dB(A)] (*)	BOX CODE
► RLS 300-400/BP MX	C7	1255	160 - 980	110	1140	1345	10	3010376

(*) Average noise reduction according to EN 15036-1 standard

Accessories for modulating operation



To obtain modulating operation, the RLS/BP MX series of burners requires a regulator with three point outlet controls. The following table lists the accessories for modulating operation with their application range.

BURNER	REGULATOR TYPE	REGULATOR CODE
► RLS 300-400/BP MX	RWF 40 Basic version with 3 position output	3010356
► RLS 300-400/BP MX	RWF 40 High version with additional modulating output and RS 485 Interface	3010357

The relative temperature or pressure probes fitted to the regulator, must be chosen on the basis of the application.



BURNER	PROBE TYPE	RANGE (°C) (bar)	PROBE CODE
► RLS 300-400/BP MX	Temperature PT 100	-100 ÷ 500°C	3010110
► RLS 300-400/BP MX	Pressure 4 ÷ 20 mA	0 ÷ 2,5 bar	3010213
► RLS 300-400/BP MX	Pressure 4 ÷ 20 mA	0 ÷ 16 bar	3010214
► RLS 300-400/BP MX	Pressure 4 ÷ 20 mA	0 ÷ 25 bar	3090873

Depending on the servomotor fitted to the burner, a three-pole potentiometer (1000 Ω) can be installed to check the position of the servomotor. The KITS available for the various burners are listed below.

BURNER	POTENTIOMETER KIT CODE
► RLS 300-400/BP MX	3010021



Low NOx Modulating Dual Fuel Burners

RLS/BP MX SERIES

Gas train accessories

LPG kit



For burning LPG gas, a special kit is available to be fitted to the combustion head on the burner.

BURNER	KIT CODE
► RLS 300-400/BP MX	20055464

Adapters

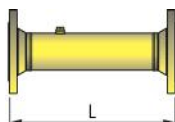

If is necessary to space out the gas train from burner an extension adapter is available.

BURNER	GAS TRAIN	ADAPTER TYPE	DIMENSIONS	L mm	ADAPTER CODE
► RLS 300-400/BP MX	VGD 50* VGDF 65* VGDF 80* VGDF 100*	I	DN 80  DN 80	400	3010222

* with and without seal control

Seal control kit



To test the valve seals on the gas train, a special "seal control kit" is available. The valve seal control device is compulsory (EN 676) on gas trains to burners with a maximum output over 1200 kW.

GAS TRAIN	KIT CODE for 50 Hz operation	KIT CODE for 60 Hz operation
► VGD type	3010367	20029057