

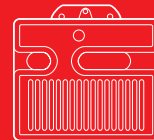

RIELLO 40 F Series

One Stage Light Oil Burners

F5	30 ÷	60 kW
F10	54 ÷	107 kW
F20	95 ÷	202 kW



COMBUSTION
TECHNOLOGY

ENQUIRIES
National Tel: +27 21 715 3171
Email: info@combustiontechnology.co.za
www.combustiontechnology.co.za



RIELLO
Energy For Life

The Riello 40 F series of one stage light oil burners, is a complete range of products developed to respond to any request for light industrial applications. The Riello 40 F series is available in three different models, with an output ranging from 30 to 202 kW, divided in three different structures.

All the models use the same components designed by Riello for the Riello 40 F series. The high quality level guarantees safe working.

In developing these burners, special attention was paid to reducing noise, to the ease of installation and adjustment, to obtaining the smallest size possible to fit into any sort of boiler available on the market.

All the models are approved by the EN 267 European Standard and conform to European Directives for EMC, Low Voltage, Machinery and Boiler Efficiency.

All the Riello 40 F burners are fired before leaving the factory.

Technical Data

MODEL		R40 F5	R40 F10	R40 F20
Burner operation mode		One stage		
Servomotor	type	===		
	run time s	===		
Heat output	kW	30 ÷ 60	54 ÷ 107	95 ÷ 202
	Mcal/h	25.8 ÷ 51.6	46.4 ÷ 92	81.7 ÷ 173.7
	Kg/h	2.5 ÷ 5	4.5 ÷ 9	8 ÷ 17
Working temperature		°C min./max. 0/40		
FUEL/AIR DATA				
Light oil	net calorific value	kWh/kg	11.8	
		kcal/kg	10200	
	viscosity at 20°C	mm ² /s (cSt)	4 ÷ 6 (at 20°C)	
Pump	type	R.B.L		
	delivery	Kg/h	30 (at 12 bar)	
Atomised pressure		bar 7 - 15		
Fuel temperature		max. °C 50		
Fuel pre-heater		NO	NO	NO
Fan		type forward tilted blades		
Air temperature		max. °C 40		
ELECTRICAL DATA				
Electrical supply		Ph/Hz/V 1/50/230 ± 10%		
Auxiliary electrical supply		Ph/Hz/V ===		
Control box		type 530 SE		
Total electrical power		kW 0.13	0.17	0.33
Total rated current		kW 0.75	0.85	1.5
Protection level		IP IP 40		
Motor electrical power		kW 0.1	0.14	0.30
Rated motor current		A 0.75	0.85	1.5
Motor start current		A 3	3.5	6
Motor protection level		IP 20		
Ignition transformer		type Incorporated in the control box		
Operation		Intermittent (at least one stop every 24h)		
EMISSIONS				
Noise levels	Sound pressure	dB (A) 60	66	73
	CO emission	mg/kWh < 60		
	grade of smoke indicator	N° Bacharach < 1		
	CxHy emission	mg/kWh < 10 (after the first 20s)		
NOx emission		mg/kWh < 250		
APPROVAL				
Directive		2006/42/EC - 2014/30/UE - 2014/35/UE		
Conforming to		EN 267		

Reference conditions:

Temperature: 20°C - Pressure: 1013,5 mbar - Altitude: 0 m a.s.l. - Noise measured at a distance of 1 meter.

Firing Rates

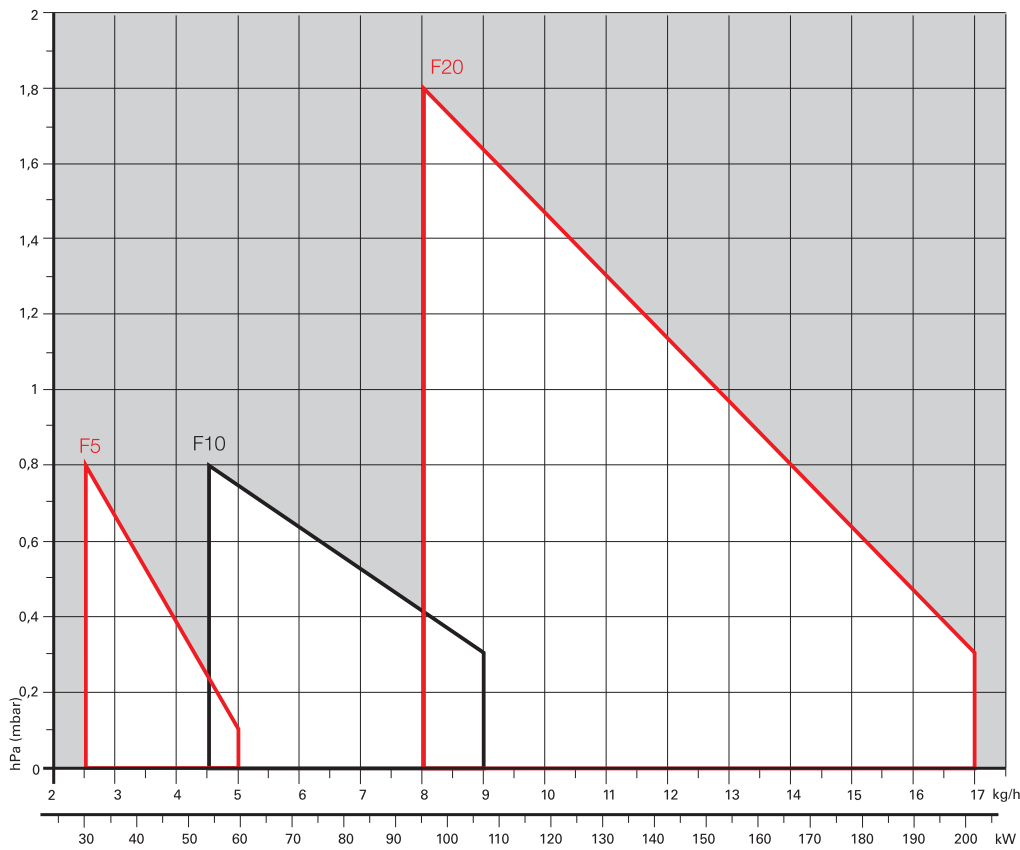

Useful working field for choosing the burner

Test conditions conforming to EN267
 Temperature: 20°C
 Pressure: 1013,5 mbar
 Altitude: 0 m a.s.l.

Fuel Supply

HYDRAULIC CIRCUIT

All the burners have a R.B.L. geared pump with safety valve on the return circuit.

F5 - F10 - F20

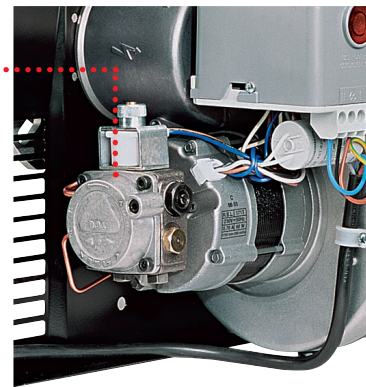
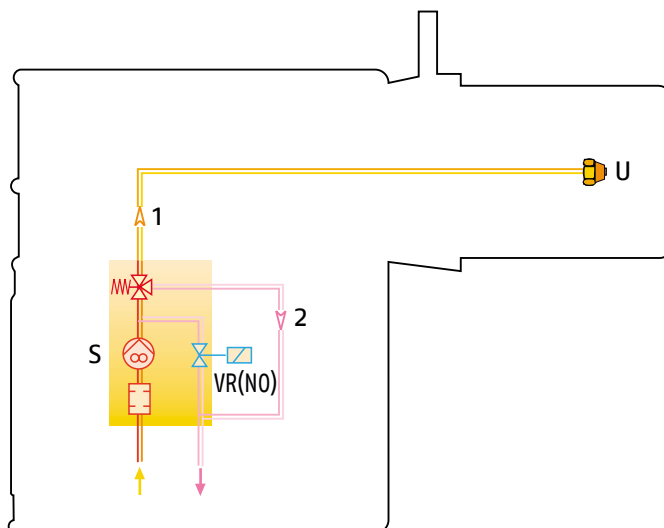

Fuel pump

Fuel feed to the burner can be from the right or the left side on all models.

S	Pump with filter and pressure regulator on the delivery pipe
VR (NO)	Oil return valve on the delivery pipe
1	Oil input pipe to the nozzle
2	Oil return pipe from the regulator
U	Nozzle

Dimensioning Of The Fuel Supply Lines

The fuel feed must be completed with the safety devices required by the local regulations in force.

The table shows the choice of piping diameter for the various burners, depending on the difference in the height between the burner and the tank and the distance between them.

Maximum equivalent length of the pipework L (m)				
	Type A system		Type B system	
Pipe size	Ø 8 mm	Ø 10 mm	Ø 8 mm	Ø 10 mm
H (m)	L _{max} (m)	L _{max} (m)	L _{max} (m)	L _{max} (m)
0	35	100	-	-
0.5	30	100	10	20
1.0	25	100	20	40
1.5	20	90	40	80
2.0	15	70	60	100
3.0	8	30	-	-
3.5	6	20	-	-

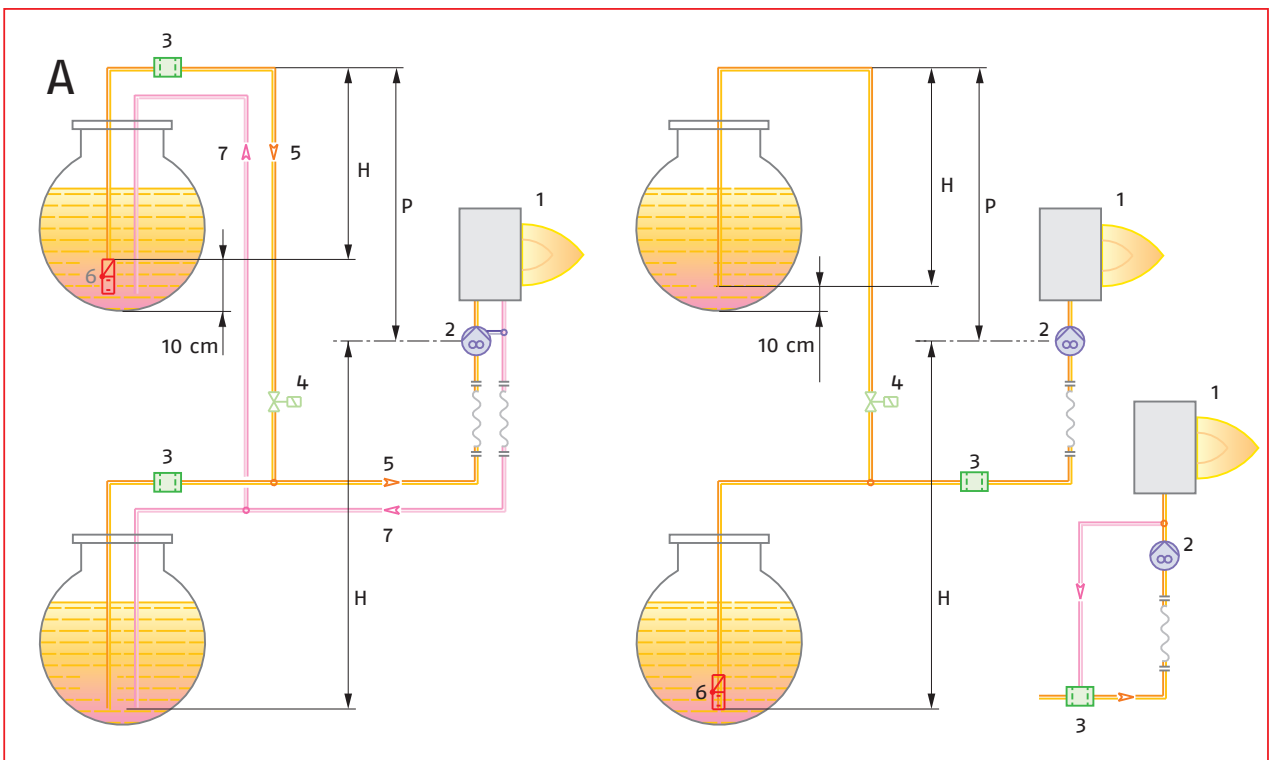

TYPE OF SYSTEM THAT CAN BE INSTALLED

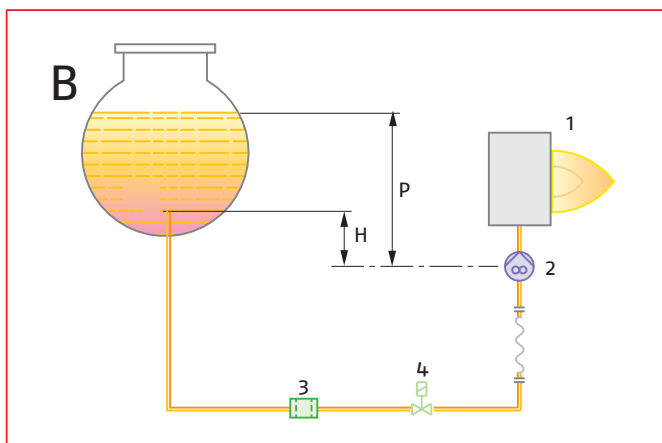

H	Pump/Foot valve height difference
Ø	Inside pipe diameter
P	Difference in height ≤ 4 m
1	Burner
2	Pump
3	Filter
4	Shut-off solenoid valve
5	Suction pipework
6	Bottom valve
7	return pipework

Ventilation

The ventilation circuits always ensure low noise levels with high performance of pressure and air delivery, inspite of their compact size.



Air suction

Combustion Head

All the models have adjustable combustion heads.

Simple adjustment to the combustion head allows adapting internal geometry of the head to the maximum rated output of the burner.

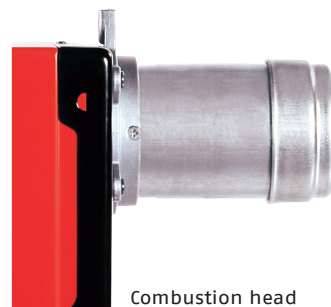

Combustion head

COMBUSTION CHAMBER DIMENSIONS USED IN THE TEST LABORATORY

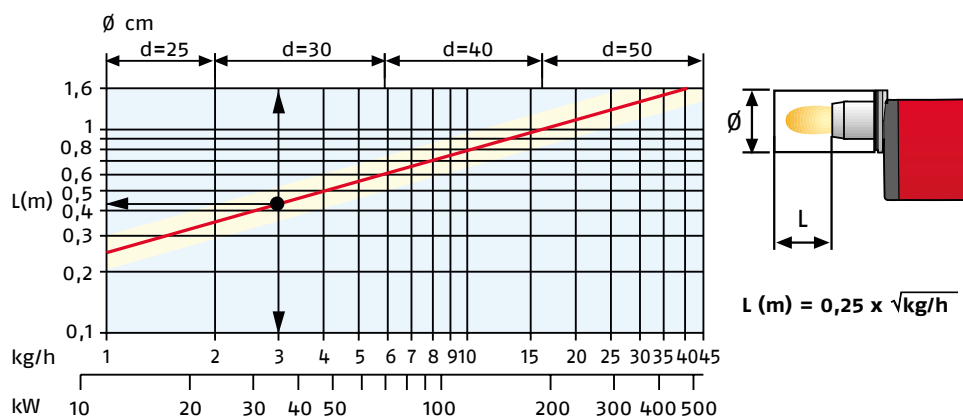

Example:
burnt thermal delivery = 3 kg/h;
 L (m) = $0.25 \times \sqrt{3} = 0.43$ (m);
 $\varnothing = 30$ (cm)

$$L \text{ (m)} = 0,25 \times \sqrt{\text{kg/h}}$$

With simple adjustments, the burner can be adapted to combustion chambers that are slightly different from those used in the tests.

Operation

BURNER OPERATION MODE

All these models are one stage operation.

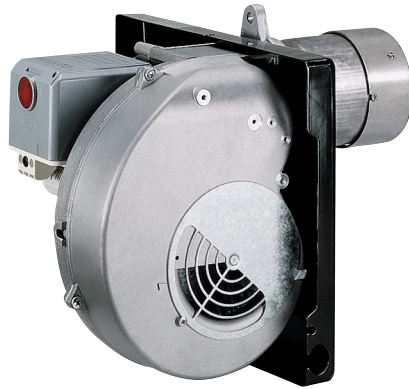

Air damper

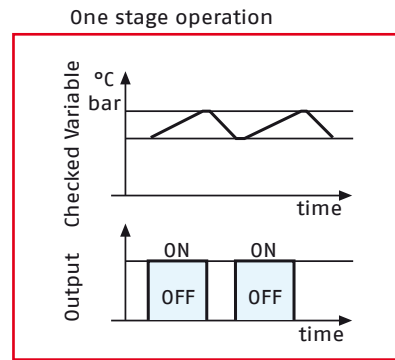

START UP CYCLE

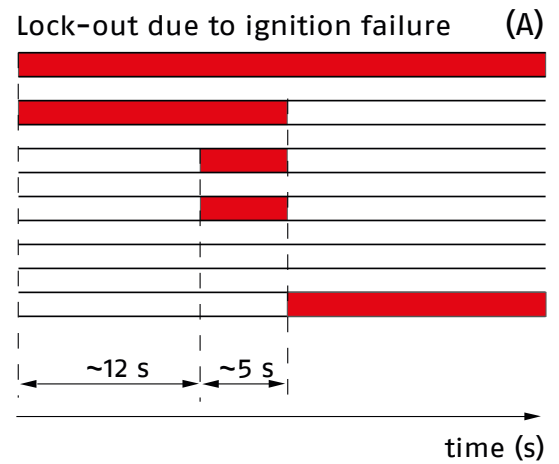
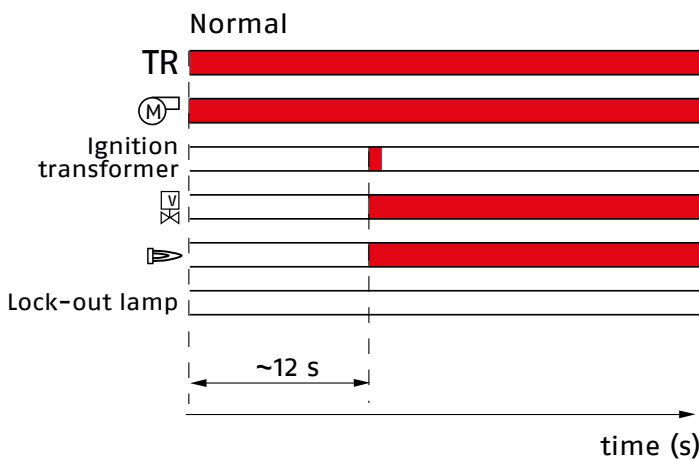

(A) Lock-out is shown by a led on the appliance.

CORRECT OPERATION

- 0s The burner begins the ignition cycle.
- 0s-12s Pre-purge with the air damper open.
- 12s Ignition.

LOCK-OUT DUE TO IGNITION FAILURE

If the flame does not light within the safety limit (~ 5s) the burner locks-out.

Emissions

The emission data has been measured in the various models at maximum output, according to EN 267 standard.

NO2 EMISSIONS

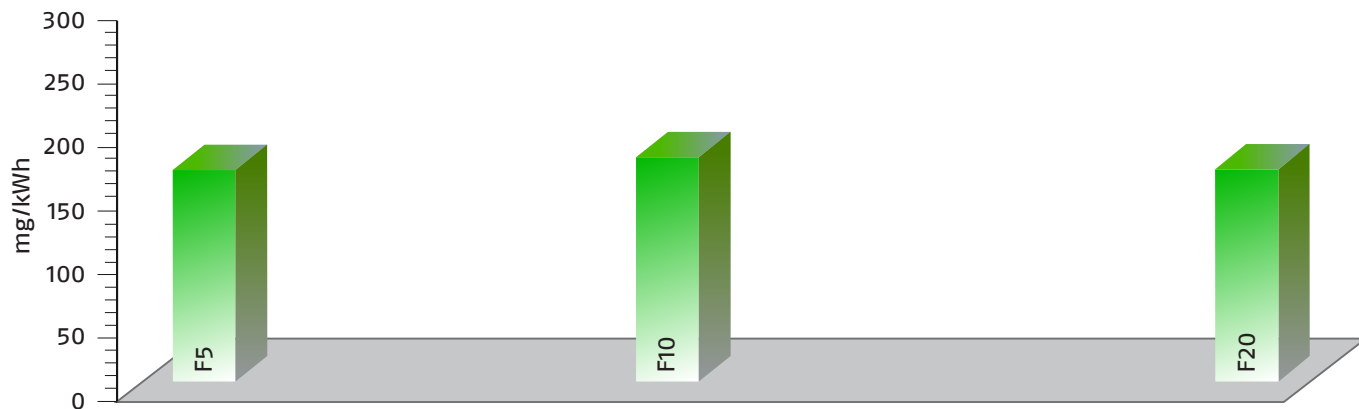

CO EMISSIONS

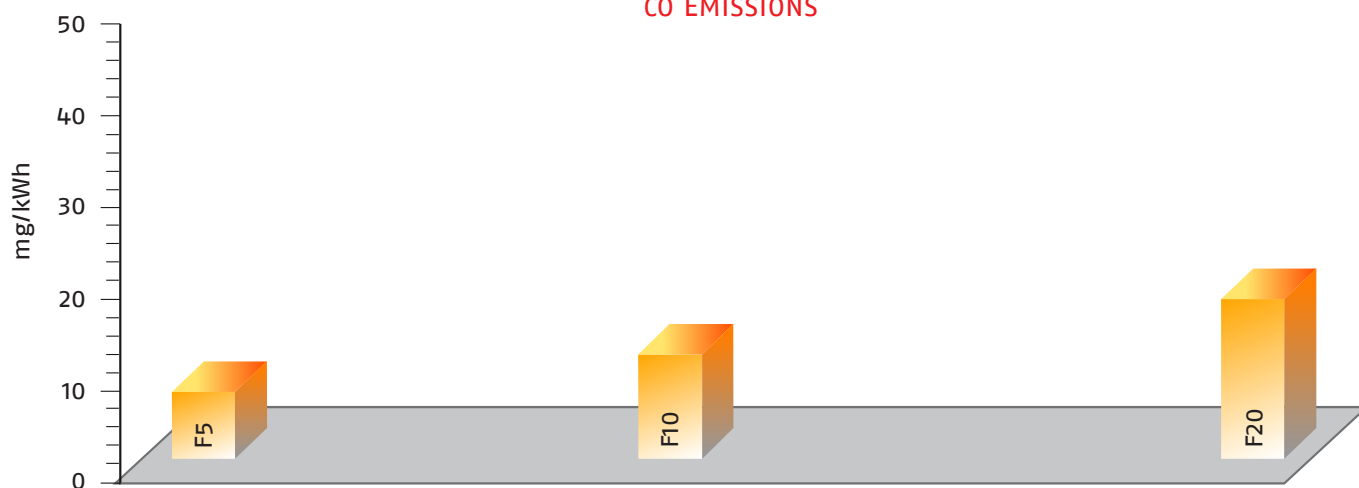

NOISE EMISSIONS

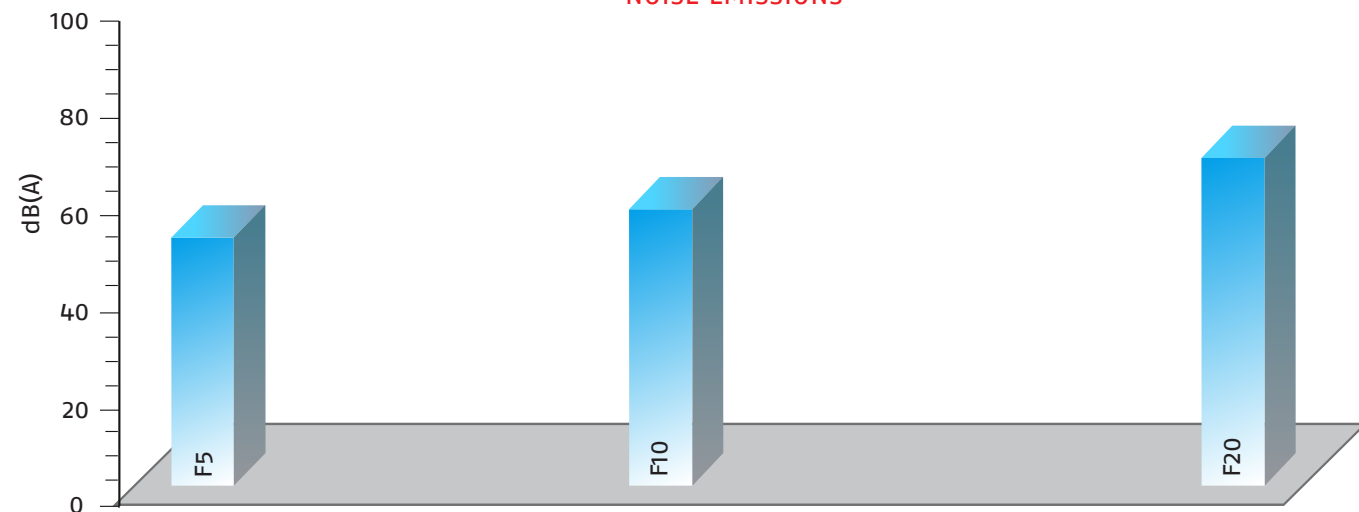

Overall Dimensions (mm)

These models are distinguished by their reduced size, in relation to their outputs, which means they can be fitted to any boiler on the market.

BURNER

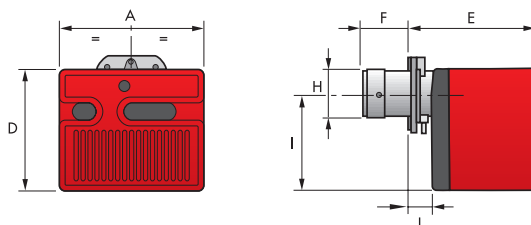

MODEL	A	D	E	F	H	I	L
F5	272	233	240	72	89	180	41
F10	305	262	265	104	105	204	44
F20	350	298	299	118	125	230	45

BURNER - BOILER MOUNTING FLANGE

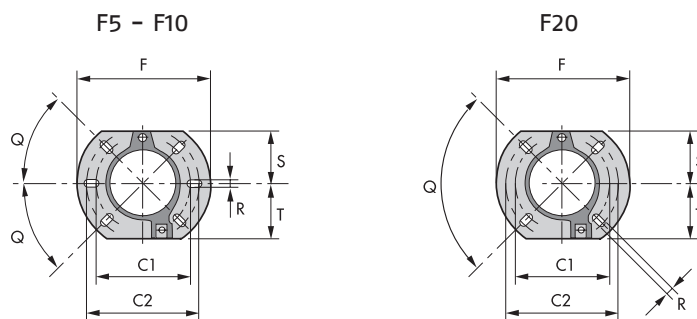

MODEL	C1	C2	F	Q	R	S	T
F5	130	150	180	45°	11	72	75
F10	140	170	189	45°	11	83	83
F20	160	190	213	90°	11	99	99

PACKAGING

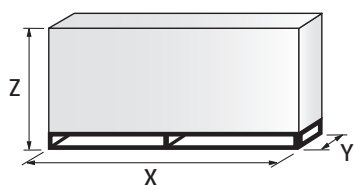

MODEL	X	Y	Z	kg
F5	383	315	325	12
F10	423	348	340	13
F20	483	393	377	16

Installation Description

Skilled and qualified personnel must perform installation, start up and maintenance. A nozzle is fitted to the burner and used for fire tests in the factory. If necessary, change the nozzle on the basis of the maximum output of the boiler. All operations must be carried in accordance with the technical handbook supplied with the burner.

BURNER SETTING

Air damper and head adjustment area are easily accessible and the operation is simple thanks to a graduated scale and following the manual instruction.

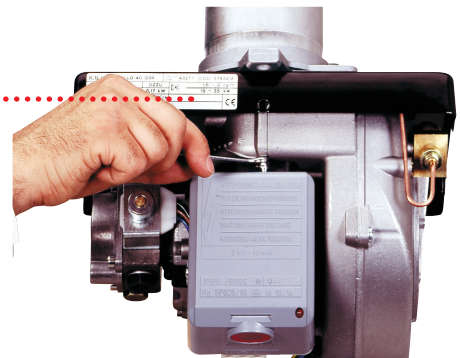
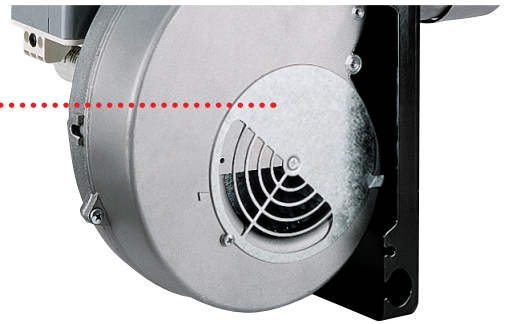

Burner accessories

REMOTE CONTROL RELEASE KIT FOR 530 SE CONTROL BOX

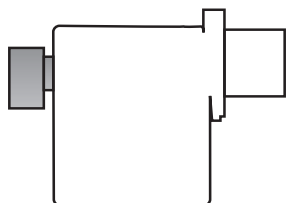

The 530 SE control box can be remotely released using an electric command kit. This kit must be installed in conformity with current regulations in force.

BURNER	CODE
F5 - F10 - F20	3001030

EXTENDED HEAD KIT

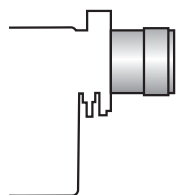

Kits of extended heads are available.

BURNER	STANDARD HEAD LENGTH (mm)	EXTENDED HEAD LENGTH (mm)	KIT CODE
F5	72	90	3006001
F5	72	90 inox	3000688
F5	72	107	3000638
F5	72	121	3000686
F5	72	121 inox	3000687
F10	104	168	3000643
F10	104	250	3000770
F20	118	178	3000644
F20	118	260	3000771

SPACER KIT

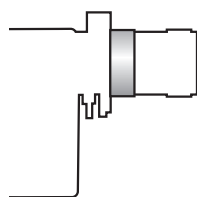

Using the special accessories, the burner can be pulled back to reduce head penetration into the combustion chamber.

BURNER	SPACER THICKNESS S (mm)	CODE
F5	25	3000642
F10	25	3000672
F20	25	3000673

INLET AIR ASPIRATION KIT

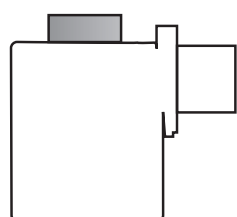

This kit allows to channel the external air directly into the burner and is available as accessory for models:

BURNER	CODE
F5	20027574
F10	20027577
F20	20027580

LIGHT OIL FILTER



For cleaning light oil from dirty particles and impurities filters with the following features are available:

BURNER	FILTERING DEGREE (μm)	CODE
All models	60	3006561

Filter made up of aluminium body and stainless steel filtering cartridge; available singularly.

BURNER	FILTERING DEGREE (μm)	CODE
All models	60	3075011

Filter made up of aluminium cover, plastic tank and nylon filtering cartridge; available in packaging of 50 pieces.

LIGHT OIL FILTER/DEGASSING UNIT



To solve problems of air or water in the oil circuit a special filter/degassing unit is available, made up of aluminium cover, plastic tank, stainless steel filtering cartridge, air release cap and water purge valve. It is available singularly.

BURNER	FILTERING DEGREE (μm)	CODE
All models	100	3000926

7-PIN PLUG KIT

If necessary a 7-pin plug kit is available (in packaging of n. 5 pieces).

BURNER	CODE
All models	300945

HOUR COUNTER KIT FOR 530 SE AND 531 SE CONTROL BOXES



To measure the burner working time a hour counter kit is available.

BURNER	CODE
All models	3000904



7-POLE SOCKET KIT FOR 530 SE AND 531 SE CONTROL BOXES

For burner without pre installed socket a 7-pole socket kit with cable is available.

BURNER	CODE
All models	3001065

BALANCED FLUE VERSION

The R40 series balanced flue oil burner has been specifically designed to meet the increasing trend towards the use of balanced flue, otherwise known as room sealed appliances, which avoid the necessity of having a chimney to discharge the products of combustion.

Balanced flue products are completely sealed from the environment in which they are installed, drawing air for combustion directly from the outside, thereby ensuring no unwelcome smells from combustion of the oil.

As a result of the burner components such as motor, oil pump etc.

being completely enclosed this provides an additional benefit of low sound levels.

The R40 balanced flue range has been designed and manufactured to meet the latest European and OFTEC test requirement and are manufactured under quality assurance standards.



Riello 40 balanced flue version

OVERALL DIMENSIONS (mm)

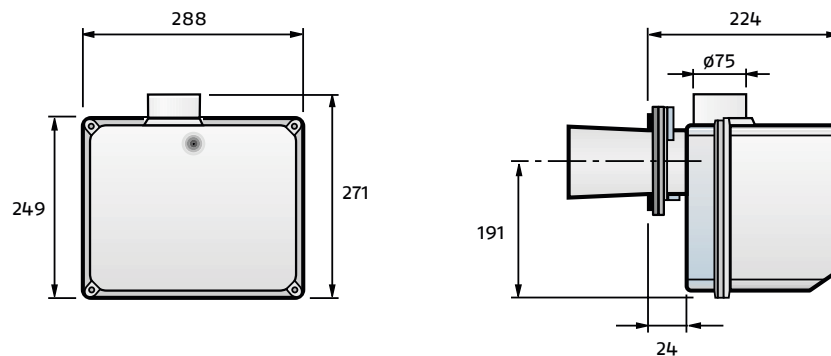

BIO FUELS

Riello Burners is able to offer technical variants which allow burners to be used within environmental heating, process or special applications. These applications now include solutions for liquid Bio fuels (i.e. biodiesel and vegetable oil).

Our experience in research and development and field applications with organic origin Bio fuels has resulted in Riello being able to offer a wide range of solutions for the combustion of Bio fuels.

KEROSENE AND ULSD

Riello 40 F series burners can be supplied, on demand, suitable for applications where combustion of Kerosene, Low Sulphur Kerosene and Ultra Low Sulphur Diesel Oil (ULSD) is the chosen fuel.

These burner variants can be provided upon request and after a technical-commercial evaluation; for more information please contact Riello Burners Commercial and Technical Department, our Application Engineers will be pleased to help you.

Specification

DESIGNATION OF SERIES

A special index will help you choose the right burner from the Riello 40 F models available. There is also a clear and detailed product specification and description.

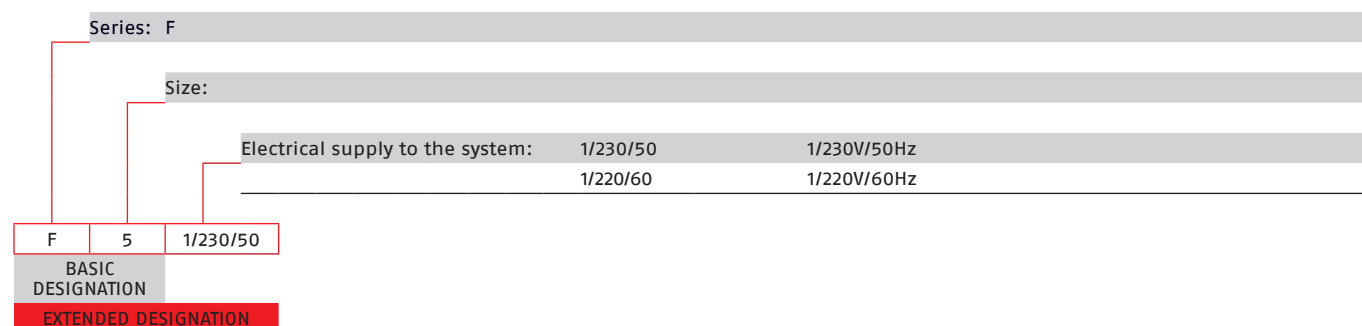

AVAILABLE BURNER MODELS

F5	1/230/50
F5	1/220/60
F10	1/230/50
F10	1/220/60
F20	1/230/50
F20	1/220/60

Net calorific value: 11,8 kWh/kg - 10200 kcal/kg -
 Viscosity at 20°C: 4÷6 mm²/s (cSt)
 The burners of F series are in according to EN 267.

STATE OF SUPPLY

Completely automatic monobloc light oil burners, one stage operation, made up of:

- Fan with forward curve blades
- Metallic cover
- Fixed air damper with adjustment
- Single phase electric motor 230 V, 50 Hz
- Combustion head fitted with:
 - stainless steel head cone, resistant to high temperatures
 - ignition electrodes
 - flame stability disk
- Geared pump for fuel supply, fitted with:
 - filter
 - pressure regulator
 - attachments for fitting a pressure gauge and vacuum meter
 - internal by-pass for preparing for single-pipe installations
- Fuel feed solenoid valve incorporated in the pump
- Photocell for flame detection
- Electronic flame control equipment
- Light oil nozzle
- IP X0D (IP 40) protection level.

Standard equipment:

- Two flexible pipes for connection to the light oil supply line
- Two nipples for connection to the pump
- Flange, screws and nuts for fixing
- Thermal screen
- Instruction handbook for installation, use and maintenance
- Spare parts catalogue.

Riello Burners a world of experience in every burner we sell.

05/2016
TS0031UK01



[1]

Across the world, Riello sets the standard in reliable and high efficiency burner technology.

With burner capacity from 5 kW to 48 MW, Riello gas, oil, dual fuel and Low Nox burners deliver unbeatable performance across the full range of residential and commercial heating applications, as well as in industrial processes.

With headquarter in Legnago, Italy, Riello has been manufacturing premium quality burners for over 90 year. The manufacturing plant is equipped with the most innovative systems of assembling lines and modern manufacturing cells for a quick and flexible response to the market.

Besides, the Riello Combustion Research Centre, located in Angiari, Italy, represents one of the most modern facility in Europe and one of the most advanced in the world for the development of the combustion technology.

Today, the company's presence on worldwide markets is distinguished by a well-constructed and efficient sales network, alongside many important Training Centres located in various countries to meet its customers' needs. Riello has 13 operational branches abroad (in Europe, America and Asia), with customers in over 60 countries.



[2]

[1] BURNERS PRODUCTION PLANT
S. PIETRO, LEGNAGO (VERONA) - ITALIA

[2] HEADQUARTER BURNERS DIVISION
S. PIETRO, LEGNAGO (VERONA) - ITALIA

COMBUSTION TECHNOLOGY

ENQUIRIES

National Tel: +27 21 715 3171

Email: info@combustiontechnology.co.za

www.combustiontechnology.co.za



Since the Company is constantly engaged in the production improvement, the aesthetic and dimensional features, the technical data, the equipment and the accessories can be changed. This document contains confidential and proprietary information of RIELLO S.p.A. Unless authorised, this information shall not be divulged, nor duplicated in whole or in part.

RIELLO